



PROJECT APPLICATION GUIDELINES

APPLICATION FORM – Aquatic Herbicide Treatment
– Aquatic Weed Harvesting

Note:

- All information requested on the application form must be provided. Incomplete applications will NOT be processed and will be returned as NOT COMPLETE.
- The property owner is responsible for ensuring that the application is complete and accurate even though the application is prepared by a contractor.
- The Ontario Ministry of Environment is the authority that specifies the chemical to be used and the chemical application rates and methods.
Contact Scott Olan, Ontario Ministry of Environment, 1259 Gardiners Road, Unit 3, Kingston, ON K7P 3J6 (619) 540-6874 Scott.Olan@ontario.ca for further information.

4. Submit completed applications to:

Realty Services
Trent-Severn Waterway
2155 Ashburnham Drive
P.O. Box 567
Peterborough, ON
K9J 6Z6
Fax: (705) 742-9644

- Fully complete name, address, telephone and email information of applicant.
- Fully complete name, address, telephone and email information of any contractor involved in the project.
- Fully complete location of worksite. Ensure municipal address (911 address) and tax assessment roll numbers are included.
- Describe project by checking all applicable boxes under "Project"
- Check nature of project – aquatic weed harvesting or aquatic weed herbicide
- Describe intended use – private, commercial or other. Please specify other. This may include communal docking, public area, etc.
- Complete signature of applicant or authorized agent. If the latter, include a letter wherein the owner of the property authorizes his/her agent.
- In the case of multiple property owners partnering in a single treatment, a single application may be submitted, but all property owners must sign the permit and pay the applicable fee.

All applications must be accompanied by:

- Fee:** Cheques must be made payable to the **Receiver General for Canada**. Applications submitted with N.S.F. cheques will not be processed and will be subject to a \$20.00 service charge
 - New Works or Repairs fronting a **Private Property** (Homes or cottages only).
\$50.00 + G.S.T. = **\$52.50**
 - New Works or Repairs for an **Existing Commercial Operation or a Community Association Facility** (Existing Marina, Resort, Common Docking Area)
\$100.00 + G.S.T. = **\$105.00**
 - A proposed **New Commercial Operation or New Community Association Facility** (New Marina, Resort, Common Docking Area)
\$250.00 + G.S.T. = **\$262.50**
- Copy of deed.**
- Copy of the property survey showing the location and dimension of the treatment area.**
- Detailed plan of the proposed work.** In addition to any information requirements specified in the submission requirements for a particular type of projects, the minimum requirements for the plan are as follows:
 - Plans may be hand drawn and labelled;
 - Labels should be neat and legible;
 - Dimensions may be in imperial or metric units;
 - All straight lines should be drawn using a straight edge;
 - Draw plans to scale wherever possible;
 - Show location of all emergent vegetation (bullrushes, etc.);
 - Show depths of water in treatment area;
 - Show property lines as dotted lines extending lines into the water;
 - All measurements are from property lines and perpendicular from upper controlled navigation level;

PROJECT GUIDELINES

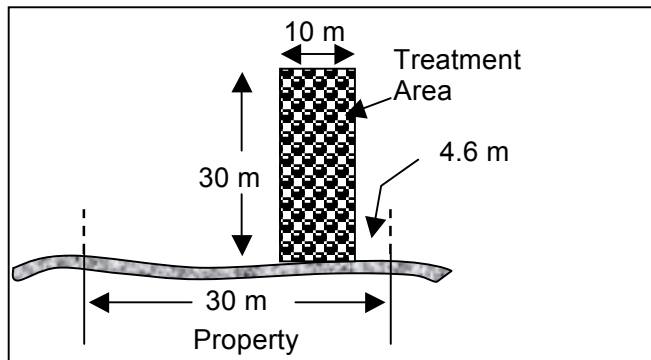

Aquatic Weed Harvesting

- The area that may be treated is 50% of the water frontage, to a maximum of 10 m (30 ft) wide.
- Harvesting may extend to 30 m (100 ft) out into the waterbody measured perpendicular from the shoreline.
- All harvesting activity will occur during daylight hours.
- Harvesting may only occur during the months of July or August.
- All harvested material must be collected and placed a minimum of 15 metres upland from the upper control water level or in accordance with the requirements of another agency, whichever is greater.
- Emergent aquatic vegetation must not be disturbed.
- Logs and rocks on the bed of the lake must not be disturbed.

Herbicide Treatment

- Herbicide is allowed only in an area that comprises no more than 50% of the water frontage size, to a maximum of 10 metres (30 feet) wide by 15 metres (50 feet) out into the water body.

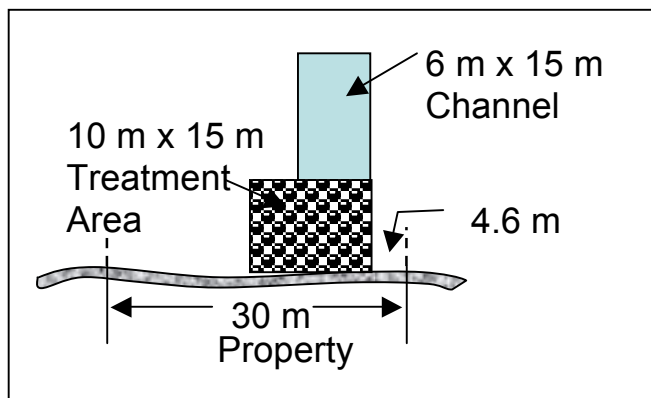

- In the case of a boat channel, a channel width of no more than a 6 metres (20 feet) may be permitted at the end of the 15 metre (50 foot) that extends into the water body.
- Application product, procedures and rates must comply with permit conditions established by the Ontario Ministry of Environment.
- Weed herbicide may only be applied during the month of July.



**AQUATIC WEED HARVESTING AND
HERBICIDE PERMIT APPLICATION
TRENT-SEVERN WATERWAY NATIONAL
HISTORIC SITE OF CANADA**

Application No (TSW use only)

**Please ensure all information is provided. Incomplete applications will not be processed
and will be returned as NOT COMPLETE.**

Name of Applicant: _____
Mailing Address: _____ Town/City _____
Postal Code: _____ Home Telephone _____ Business Telephone _____
Fax _____ Email _____
Contractor (if applicable) Clean Lake Contactor Address P.O. Box 441
Town/City Bridgenorth Postal Code KOL 1H0
Business Telephone 705 933 4219 Email info@cleanlake.ca Fax 705 417 1912

Location of work site:
Street Address (911 Address) _____ Municipality/Township _____
County _____ Lot _____ Concession _____ Lot and Registered Plan _____
Water body _____ Assessment Roll Number _____

Project (Check all that apply)

- 1. ~ Aquatic weed harvesting
- 2. ~ Aquatic weed herbicide application

Intended Use

- ~ Private ~ Commercial
- ~ Other (specify) _____

Status of Project

- ~ New ~ Repeat

Sketch of Application Area (See guidelines)

Signature of Applicant(s) or Authorized Agent _____ Date _____

Date _____

Date _____

Cross Reference (TSW use only)

Air photo Reference No. _____

CEAA (TSW use only)

~ In registry Date entered _____
~ Removed from registry
Registry reference # _____